

durietta 0

STAINLESS STEEL

MULTISTAGE PUMPS

A solid pump for superior hygiene

The durietta 0 is a close-coupled end-suction multistage centrifugal pump created for all kinds of low-flow, high-head applications that call for sanitary pump equipment.

Designed to food technology standards

The durietta 0 is designed in compliance with food technology requirements, making it ideal for jobs where hygiene is a key concern. For example, it is CIP and SIP-capable in line with the performance characteristics outlined for pumps in DIN 12462.

High-quality stainless steel

The durietta 0 is made from high-quality stainless steel to ensure reliable, hygienic, non-corrosive operation. It boasts inter-stage, discharge and suction casings and impellers manufactured from deep-drawn rolled stainless steel 1.4404 / AISI 316 L or 1.4571 / AISI 316 Ti.

Shaft seal to suit your media

The shaft seal used in the durietta 0 pump is a single, internal mechanical seal positioned in the media flow. This ensures excellent cooling and easy cleaning. The materials are selected to be compatible with the media you need to pump.

Flexible installation

The durietta 0 is available for vertical or horizontal installation, allowing you to choose the pump that best suits your system design.

Application areas

Drinking water
Process water
Filters
Bottling systems
Plate heat exchangers
Aggressive liquids (ask for a media-resistance table)



TECHNICAL DATA

durietta 0 pumps

Head: up to 70 m
Flow rate: up to 6 m³/h
Operating pressure: up to 10 bar
Operating temperature: 95°C (up to 120°C on request)

PERFORMANCE CURVE

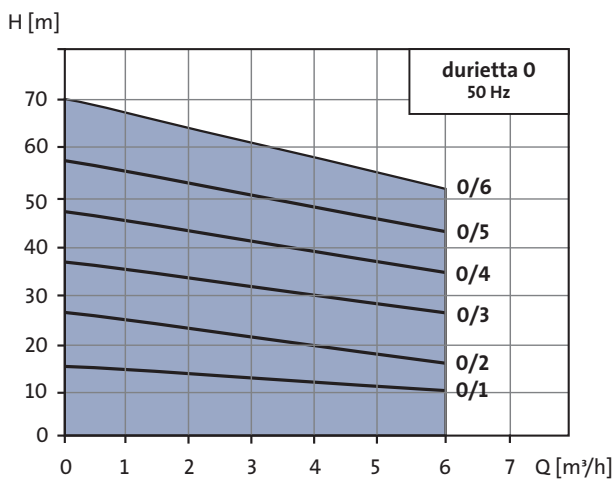

MATERIALS

Pos.	Component	Material	EN DIN
1	Impeller	CrNiMo steel	1.4404
2	Pump housing	CrNiMo steel	1.4404
3	Shaft seal	SiC/SiC Carbon/stainless steel Carbon/SiC EPDM or FKM	
4	Pump shaft	CrNiMo steel	1.4571
5	Motor		
6	Support	Stainless steel	1.4307
7	Shroud		

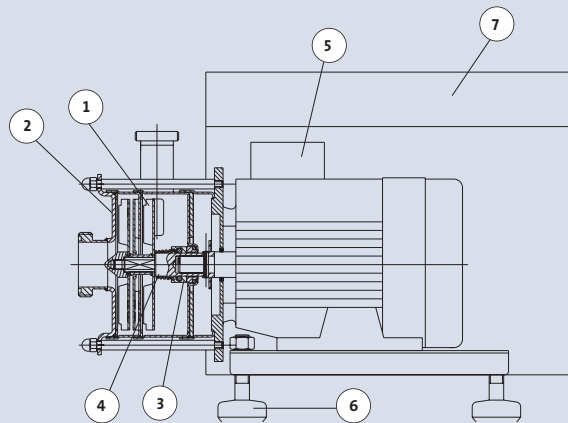

The Grundfos sanitary range

The Grundfos range of sanitary pumps is brought to you by two companies with a long history of giving customers the best. Grundfos has developed reliable pumps for industry customers for more than five decades, and now those customers can benefit from the acclaimed Hilge range of customised and high-grade stainless steel sanitary pumps for the food, beverage and life-science industries.

Examples include the multistage Contra, the self-priming SIPLA, and the single-stage MAXA/MAXANA. Every model exemplifies the quality you would expect from a Grundfos/Hilge partnership.

For further information on the Grundfos sanitary range, contact your local dealer or visit www.grundfos.com



durietta 0



96 62 59 65 03 06